

Model SH

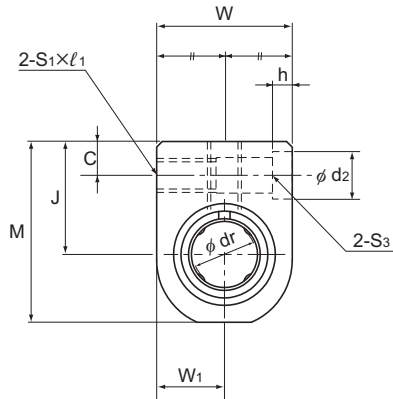

Model SH

Model No.	Outer dimensions			LM casing dimensions					
	Height	Width	Length	Mounting hole position			Tap		Through bolt
	M	W	L	B	B ₁	C	S ₁ × l ₁	S ₂ × l	model No, S ₃
SH 3UU	14	10	13	—	8	3	M3 × 6	M3 × 5.5	M2
SH 4UU	16	12	15	—	10	3	M3 × 6	M3 × 6	M2
SH 5UU	18	14	17	—	12	3	M3 × 6	M3 × 6	M2
SH 6UU	22	16	24	18	9	5	M4 × 8	M4 × 8	M3
SH 8UU	26	20	27	20	10	5	M4 × 8	M5 × 8.5	M3
SH 10UU	32	26	35	27	15	6	M5 × 10	M6 × 9.5	M4
SH 12UU	34	28	35	27	15	6	M5 × 10	M6 × 9.5	M4
SH 13UU	36	30	36	28	16	6	M5 × 10	M6 × 9.5	M4
SH 16UU	42	36	40	32	18	6	M5 × 10	M6 × 10	M4
SH 20UU	49	42	44	36	22	7	M6 × 12	M6 × 12	M5

Notes: Since this model contains a synthetic resin retainer, do not use it at temperature exceeding 80°C.

A stainless steel Linear Bushing model LM-MG, which is highly corrosion resistant, can also be incorporated at your request.

Example of Model Number for Use in Combination with Linear Bushing Units

Linear Bushing to be combined	Example of model No.	
Both end attached with seal	SH 13UU	Standard stock
Without seal	SH 13	Build to order
Made of stainless steel; both end attached with seal	SH 13MUU	Build to order

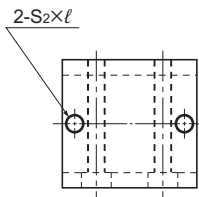
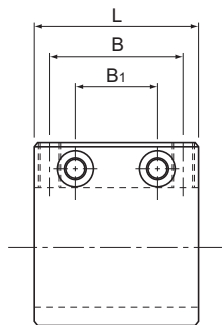

Top surface of models SH6 to SH20

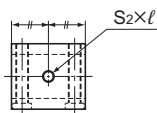

Top surface of models SH3 to SH5

Unit: mm

	Center height J ± 0.02	W_1 ± 0.02	d_2	h	Inscribed bore diameter		Model No. of Linear Bushing to be combined	Basic load rating		Unit	
					dr	Tolerance		C	C_0	Mass g	
								N	N		
	9	5	4.2	1.5	3	0 -0.008	LM3UU	88.2	108	4.5	
	10	6	4.2	1.5	4		LM4UU	88.2	127	7	
	11	7	4.2	1.5	5		LM5UU	167	206	11	
	14	8	6.5	3.3	6	0 -0.009	LM6UU	206	265	21	
	16	10	6.5	3.3	8		LM8UU	265	402	34	
	19	13	8	4.4	10		LM10UU	373	549	67	
	20	14	8	4.4	12		LM12UU	412	598	74	
	21	15	8	4.4	13		LM13UU	510	775	91	
	24	18	8	4.4	16		LM16UU	775	1180	157	
	28	21	9.5	5.4	20		0 -0.010	LM20UU	863	1370	206